

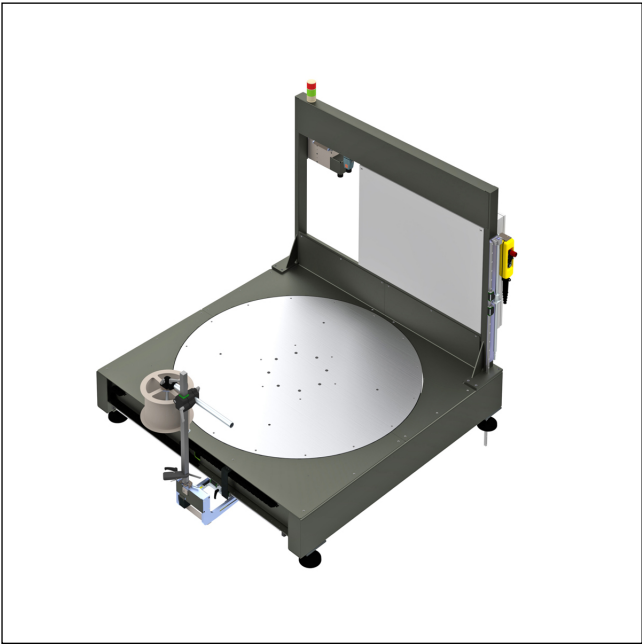

Feeding Systems for Components in Unitized Arrangement



Reel decoiler, horizontal, single

Approvals: 

71

7150 4

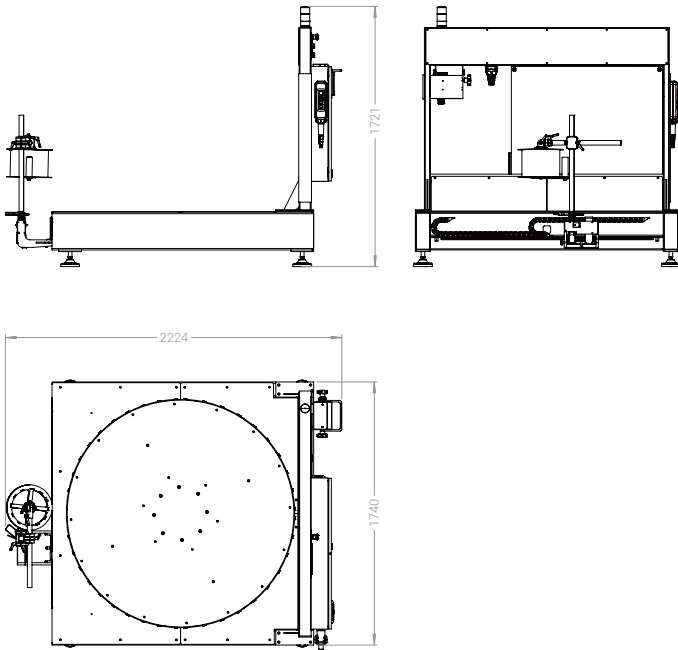

Features

Application

- Feeding of coiled raw material (single reel or multicoil) directly from pallet
- To balance varying reel-off and drawoff speeds
- Robust machine construction with high load capacity

Scope of functions and delivery

- **Rotary table**
 - Diameter: 1500 mm
 - Load: ≤ 3000 kg
 - Rotational speed: ≤ 9 rpm
 - Sense of rotation: clockwise or counterclockwise
- **Strap takeoff**
 - Strap thickness: ≤ 1.5 mm
 - Strap width: ≤ 100 mm
 - Strap speed adjustable, ≤ 9 m/min (with inner diameter 300 mm)
 - Strap tension control
 - Strap end detection
 - Pneumatically controlled dancer regulation
 - Idler pulley adjustable
- **Language**
 - Machine: English and German
 - Operation manual: English and German

Options

- Rewinder for interlayer paper, adjustable in speed and height, with paper crack resp. paper end detection
- Strap takeoff for perforated strap
- Additional language packs

Dimensions and supply data

Dimensions (H x W x D)	ca. 1721 mm x 1740 mm x 2225 mm
Weight	ca. 1300 kg
Electrical supply	400 V AC/50 Hz, 16 A
Compressed air supply	6 bar