

71

7150 2

Feeding Systems for Coiled Goods



Double reel decoiler

Approvals: 

71

7150 2

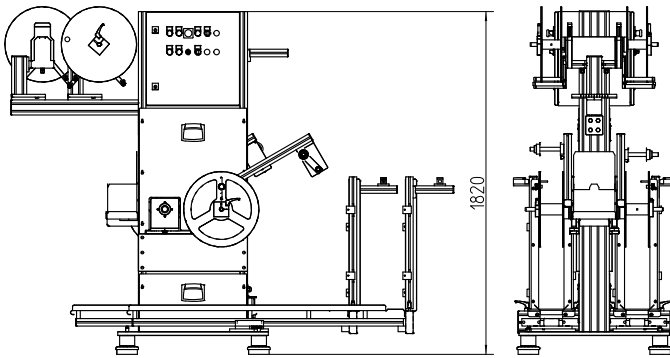

Features

Application

- Feeding of components on reel
- To balance varying reel-off and drawoff speeds
- Line buffer reduces or prevents down times when changing reels

Options

- Reel decoiler system, dual layout for two reels
- Reel-specific details according to requirements
- Can perfectly be combined with an automatic welding station for uninterrupted feeding when changing reels

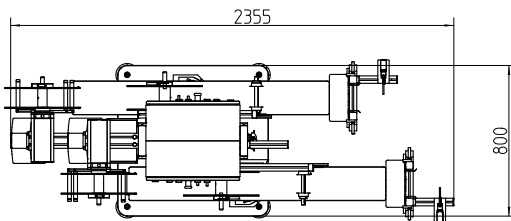

Dimensions and supply data

Dimensions (H x W x D)

ca. 1820 mm x 2355 mm x 800 mm

Weight

ca. 430 kg

Electrical supply

230 V AC